

MILL DRILL MACHINE HM-48B

Order Code: (K8742D)

Edition : 1.0
Date: (05/24)

The following section covers the spare parts diagrams and lists that were current at the time this manual was originally printed. Due to continuous improvements of the machine, changes may be made at anytime without notification.

HOW TO ORDER SPARE PARTS

1. Have your machines model number, serial number & date of manufacture on hand, these can be found on the specification plate mounted on the machine
2. A scanned copy of your parts list/diagram with required spare part/s identified.

NOTE: SOME PARTS MAY ONLY BE AVAILABLE AS AN ASSEMBLY

3. Go to www.machineryhouse.com.au/contactus and fill out the inquiry form attaching a copy of scanned parts list.



WARNING!

*Electricity is dangerous and could cause death
All electrical work must be carried out by a qualified electrician.*



CAUTION

It is impossible to cover all possible hazards Every workshop enviroment is different. These are designed as a guide to be used to compliment training and as a reminder to users prior to equipment use. Always consider safety first, as it applies to the individual working conditions.

ELECTRICAL DIAGRAM HM-48B

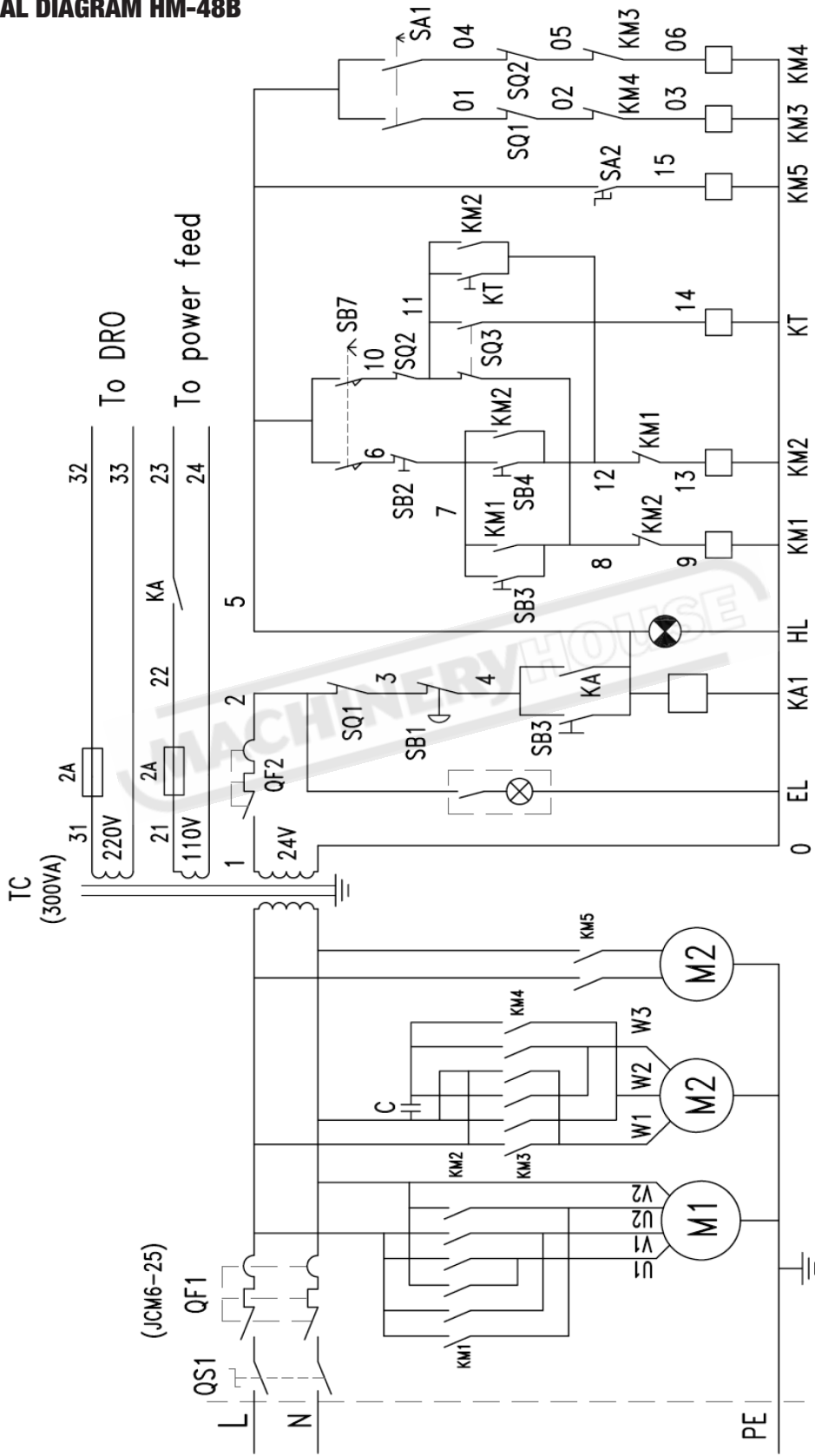

WIRING DIAGRAM HM-48B

SPARE PARTS HEAD DIAGRAM HM-48B

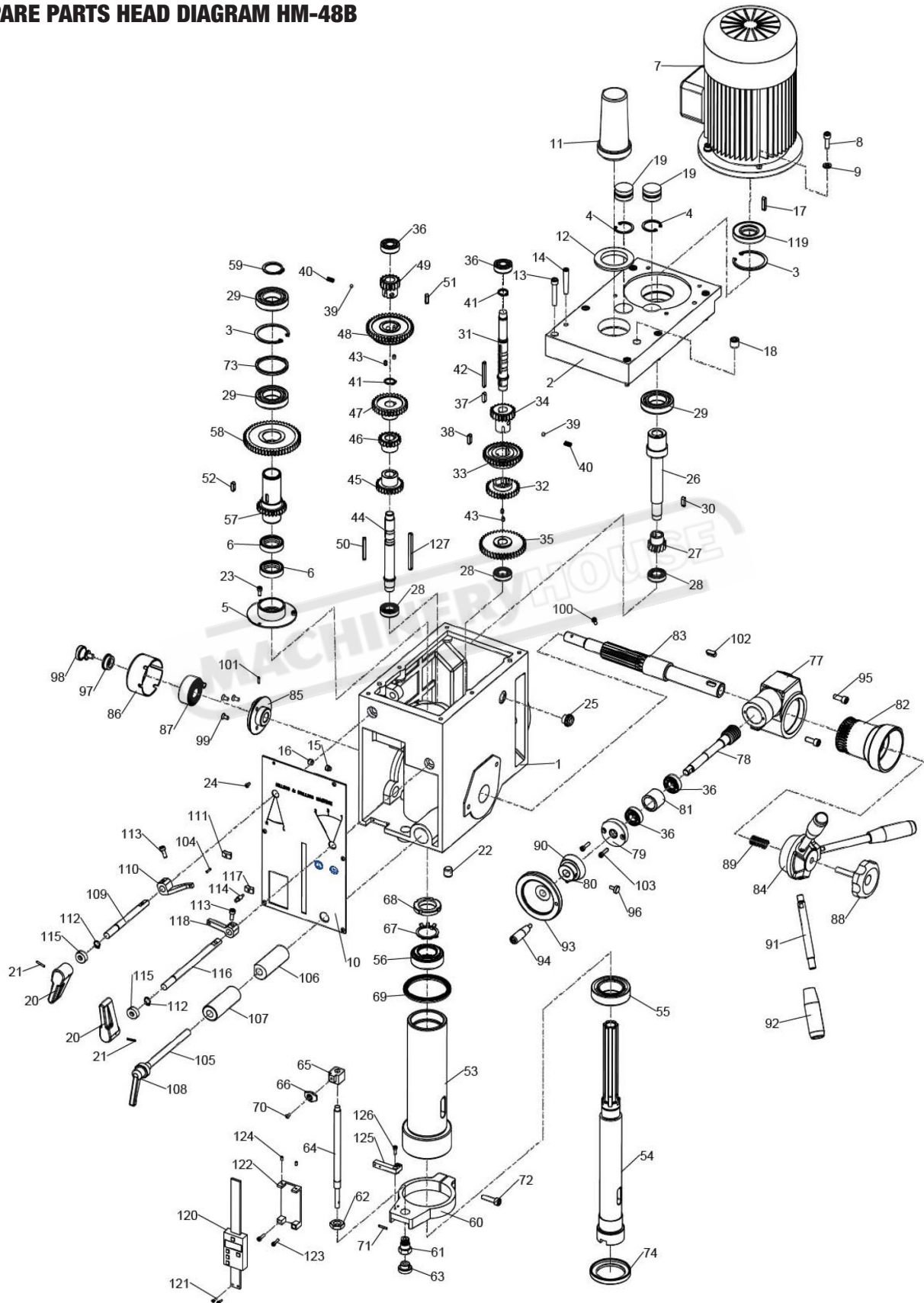

SPARE PARTS LIST FOR HEAD HM-48B

NO.	DESCRIPTION	SIZE	QTY	NO.	DESCRIPTION	SIZE	QTY
1	Head body	20010B	1	37	Key	6X14	1
2	Head Body Cover	20011B	1	38	Key	6X28	1
3	Int Retaining Ring	Ø62	2	39	Ball	Ø8	2
4	Int Retaining Ring	Ø35	2	40	Spring		2
5	Airtight Base	20018B	1	41	Ext Retaining Ring	Ø18	2
6	Airtight Ring	45x35X10	2	42	Key	5X50	1
7	Motor	1.5KW	1	43	Screw	M6X12	4
8	Screw	M8X25	1	44	lii Shaft	20107B	1
9	Washer	8	1	45	Gear Z25	20109-B	1
10	Plate	20201	1	46	Gear Z18	20110-2-B	1
11	Arbor Bolt Cover	20304-1B	1	47	Gear Z32	20112-B	1
12	Arbor Bolt Cover Base	20304-2B	1	48	Gear Z43	20113-B	1
13	Screw	M8X45	6	49	Gear Z16	20115-B	1
14	Pin	8x40	2	50	Key	5X50	1
15	Screw	M10x10	1	51	Key	6X18	1
16	Screw	M10x8	1	52	Key	6X18	1
17	Key	6X28	1	53	Spindle Sleeve	20019	1
18	Bolt	ZG3/8"	1	54	Spindle	20104B	1
19	Cap	20020B	2	55	Bearing	30207 /P5	1
20	Speed Lever	20307B	2	56	Bearing	30206 /P5	1
21	Pin	3X18	2	57	Splined Sleeve Z25	20114-B	1
22	Oil Plug	ZG3/8"	1	58	Gear Z53	20116-B	1
23	Screw	M5x10	3	59	Ext Retaining Ring	Ø35	1
24	Screw	M4X8	6	60	Feed Base	20012	1
25	Oil Pointer	M18X1.5	1	61	Support Base	20128	1
26	I Shaft	20105B	1	62	Nut	20129	1
27	Gear Z14	20105-1-B	1	63	Knob	20130	1
28	Bearing	6003 / P5	3	64	Graduated Rod	20131	1
29	Bearing	6007 / P5	3	65	Fixed Bolt	20021	1
30	Key	5X25	1	66	Scale Board	20132	1
31	li Shaft	20106B	1	67	Lock Washer	Ø30	1
32	Gear Z29	20108-B	1	68	Lock Nut	M30X1.5	1
33	Gear Z35	20110-1-B	1	69	Rubber Washer	20308	1
34	Gear Z21	20111-B	1	70	Screw	M4X8	1
35	Gear Z41	20106-1-B	1	71	Split Pin	3X18	1
36	Bearing	6202 / P5	4	72	Bolt	M8X30	1

NOTE: SOME INDIVIDUAL PARTS MAY ONLY BE AVAILABLE AS AN ASSEMBLY

SPARE PARTS LIST FOR HEAD HM-48B

NO.	DESCRIPTION	SIZE	QTY	NO.	DESCRIPTION	SIZE	QTY
73	Separating Ring	20024B	1	108	Adjust Handle		1
74	Bearing Cover	20133B	1	109	Lever Shaft	20125B	1
75	Screw (R8)	M5X6	1	110	Lever	20022-1B	1
76	Pin (R8)	M5X4	1	111	Lever Bracket	20204-2B	1
77	Worm Wheel Box	20015	1	112	Ext Retaining Ring	12	2
78	Worm Shaft	20119	1	113	Screw	M6X16	2
79	Worm Cover	20302	1	114	Lever Rod	20204-3B	1
80	Screw	M6X12	1	115	Oil Seal	12X22X8	2
81	Separating Ring	20120	1	116	Long Lever Shaft	20126B	1
82	Worm Wheel	20016	1	117	Lever Bracket	20204-1B	1
83	Pinion Shaft	20117	1	118	Lever	20022-2B	1
84	Handle Body	20013	1	119	Oil Seal	35x62x10	1
85	Spring Base	20118	1	120	Digital Display		1
86	Spring Cap	20123	1	121	Screw	M3X10	2
87	Spring Plate	20122	1	122	Stents	20010C2	1
88	Big Ripple Handle	20303	1	123	Screw	M4X16	2
89	Compression Spring		1	124	Screw	M4X10	2
90	Graduated Plate	20017	1	125	Connecting Rod	20010C3	1
91	Handle Rod	20121B	1	126	Screw	M4X12	2
92	Handle Ball	20301B	1	127	Key	6X70	1
93	Handle Wheel	20306B	1				
94	Handle Rod	20305-B	1				
95	Screw	M8X25	2				
96	Screw	10107	1				
97	Washer	203063	1				
98	Screw	203066	1				
99	Screw	M6X12	3				
100	Screw	M5X12	1				
101	Pin	3X12	2				
102	Key	8X20	1				
103	Screw	M5X20	2				
104	Pin	3X15	1				
105	Fixed Bolt	20124B	1				
106	Fixed Tight Block	20203B	1				
107	Fixed Tight Block	20202B	1				

NOTE: SOME INDIVIDUAL PARTS MAY ONLY BE AVAILABLE AS AN ASSEMBLY

TABLE & COLUMN SPARE PARTS DIAGRAM HM-48B

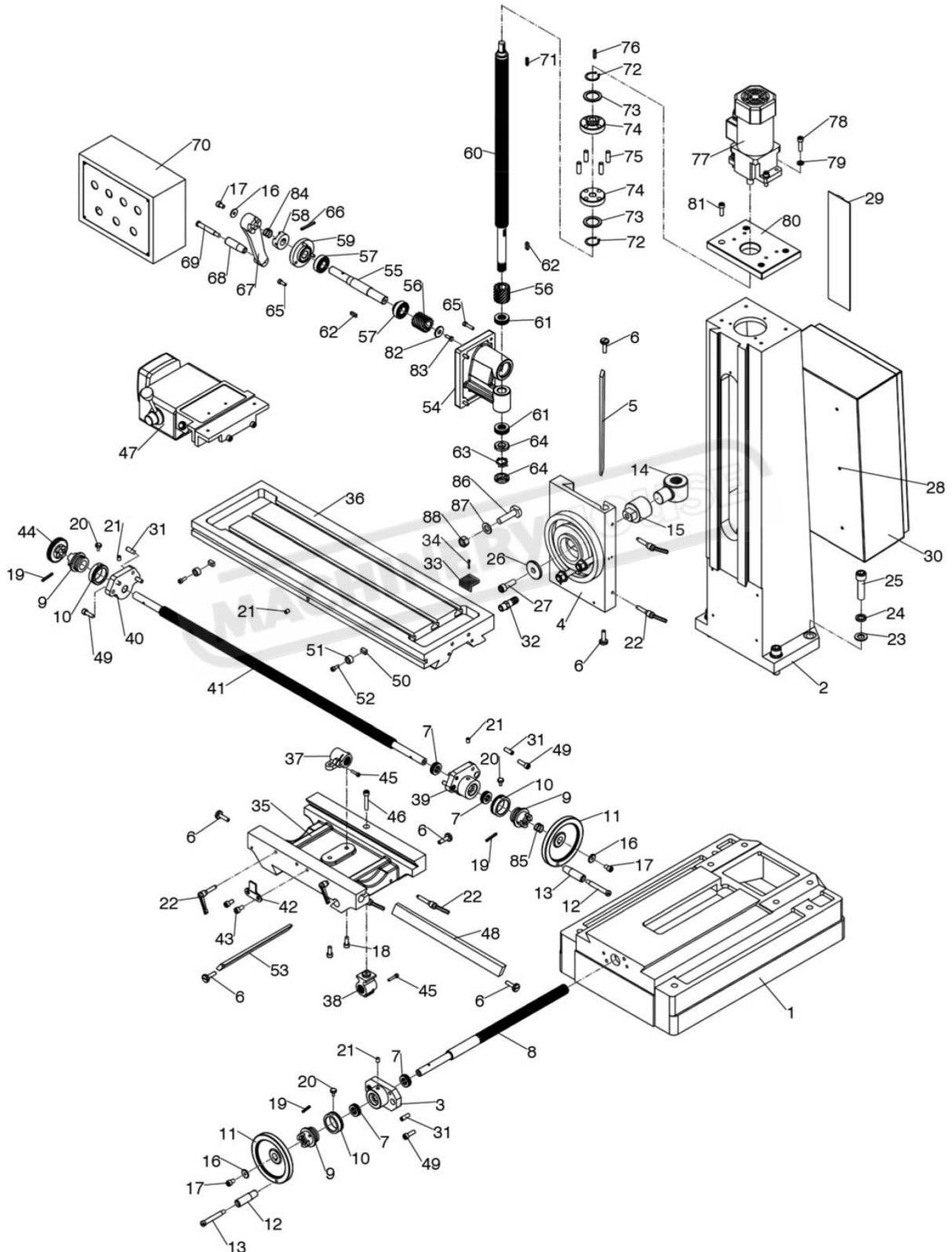

SPARE PARTS LIST FOR COLUMN & TABLE HM-48B

NO.	DESCRIPTION	SIZE	QTY	NO.	DESCRIPTION	SIZE	QTY
1	Base	10010	1	45	Screw	M5X20	2
2	Column	10013	1	46	Screw	M8X45	1
3	Square Flange	10021	1	47	Power Feed	135LBS	2
4	Raise And Lower Base	10016	1	48	Gib Strip	10022	1
5	Gib Strip	10025	1	49	Screw	M8X25	6
6	Screw	10106	6	50	Movable Fixed Block	10108	2
7	Bearing	51103	4	51	Fixed Block Support	10109	2
8	Table Screw	10104	1	52	Screw	M6X16	2
9	Dial Clutch	10102	3	53	Gib Strip	10023	1
10	Graduated Plate	10111	3	54	Raise & Lower Base	10017	1
11	Wheel	10301	2	55	Shaft	10113	1
12	Turn Handle	20305-1B	2	56	Gear	20109	2
13	Screw	20305-2B	2	57	Bearing	6004	2
14	Nut	10024	1	58	Dial Clutch	450209	1
15	Nut Bracket	10117	1	59	Flange	10015	1
16	Washer	6	3	60	Raise & Lower Screw	10016	1
17	Screw	M6X16	3	61	Bearing	51104	2
18	Screw	M8X25	2	62	Key	6 X 20	2
19	Pin	5X35	3	63	Lock Washer	20	1
20	Screw	10107	3	64	Lock Nut	M20X1.5	2
21	Oil Cup	8	4	65	Screw	M6 X 25	7
22	Fixed Handle	M8	6	66	Pin	5 X 40	1
23	Washer	16	4	67	Heaf Handle	10018	1
24	Washer	16	4	68	Turn Handle	10018.1	1
25	Bolt	M16X60	4	69	Screw M10	10018.2	1
26	Washer	10120	1	70	Electrical Box		1
27	Screw	M12X35	1	71	Key	5X22	1
28	Screw	M6x12	6	72	Retaining Ring	30	2
29	Protecting Cover	10124	1	73	Washer	10152	2
30	Electrical Box	10119	1	74		10150	2
31	Pin	8X30	6	75		10151	4
32	Pipe Joint		1	76	Key	5X25	1
33	Filter Screen		1	77	90w220v60hz1ph	Motor	1
34	Table Nut	M3X25	2	78	Screw	M8X25	4
35	Center Base	10011	1	79	Washer	M8	4
36	Table	10012	1	80	Motor Mount	10014	1
37	Table Nut	10202	1	81	Screw	M8 X 25	4
38	Table Base Nut	10203	1	82	Washer	M8	1
39	Right Flange	10020	1	83	Screw	M8 X 25	1
40	Left Flange	10019	1	84	Spring	450209.2	1
41	Table Screw	10103	1	85	Spring	10102.2	1
42	Fixed Block	10105	1	86	T-Screw	M14x55	3
43	Screw	M8x16	2	87	Washer	M14	3
44	Gear		1	88	Nut	M14	3

NOTE: SOME INDIVIDUAL PARTS MAY ONLY BE AVAILABLE AS AN ASSEMBLY